

The OAR Model of Neural Informatics for Internal Knowledge Representation in the Brain

Yingxu Wang, University of Calgary, Canada

ABSTRACT

The cognitive models of information representation are fundamental research areas in cognitive informatics, which attempts to reveal the mechanisms and potential of the brain in learning and knowledge representation. Because memory is the foundation of all forms of natural intelligence, a generic model of memory, particularly the long-term memory, may explain the fundamental mechanism of internal information representation and the forms of learning results. This article presents the Object-Attribute-Relation (OAR) model to formally represent the structures of internal information and knowledge acquired and learned in the brain. The neural informatics model of human memory is introduced with particular focus on the long-term memory. Then, the OAR model that explains the mechanisms of internal knowledge and information representation in the brain is formally described, and the physical and physiological meanings of this model are explained. Based on the OAR model, knowledge structures and learning mechanisms are rigorously explained. Further, the magnitude of human memory capacity is rigorously estimated on the basis of OAR, by which the memory capacity is derived to be in the order of $10^{8.432}$ bits.

Keywords: AI; cognitive informatics; cognitive models of the brain; intelligence science; internal information representation; knowledge engineering; knowledge representation; learning mechanisms; memory architecture; memory capacity; natural intelligence; neural informatics; OAR model; software engineering

INTRODUCTION

Cognitive models of internal information and knowledge presentation in human brains are fundamental issues in cognitive informatics, neuropsychology, cognitive science, computing, software engineering, and knowledge engineering. It is identified that the number of neurons in an adult brain is in the order of 100 billion (10^{11}), and each neuron is connected to a

large number of other neurons via several hundred to a few thousand synapses (Marieb, 1992; Pinal, 1997; Rosenzweig, Leiman, & Breedlove, 1999; Smith, 1993; Sternberg, 1998). However, the magnitude of memory capacity of human brains is still a mystery. This is mainly because the estimation of this factor is highly dependent on suitable cognitive and mathematical models of the brain, particularly how information and

knowledge are represented and stored in the memory.

It is commonly understood that memory is the foundation of all forms of natural intelligence. Although the magnitude of the neural networks and their concurrent behaviors are extremely powerful as a whole, the elementary function and mechanism of the brain are quite simple (Gabrieli, 1998; Harnish, 2002; Kotulak, 1997; Leahey, 1997; Matlin, 1998; Payne & Wenger, 1998; Turing, 1936). This view can be formally stated in the following theorem and explained in the mathematical models of human memory developed throughout this article.

- **Theorem 1:** The *quantitative advantage* of human brain states that the magnitude of the memory capacity of the brain is tremendously larger than that of the closest species; the *qualitative advantage* of human brain states that the possession of the abstract layer of memory and the abstract reasoning capacity makes human brain profoundly powerful on the basis of the quantitative advantage.

This article presents the OAR model to formally represent the structures of internal information and knowledge acquired and learned in the brain. The neural informatics model of human memory is introduced, and particular focus is put on the long-term memory and action buffer memory. Then, the OAR model that explains the mechanisms of internal knowledge and information representation in the brain is formally described, and the physical and physiological meanings of this model are explained. Based on the OAR model, knowledge structures and learning mechanisms are rigorously explained. Further, the magnitude of human memory capacity is estimated on the basis of OAR, by which the memory capacity is rigorously derived.

NEURAL INFORMATICS MODELS OF MEMORY

- **Definition 1:** *Neural Informatics* (NeI) is a new interdisciplinary enquiry of the

biological and physiological representation of information and knowledge in the brain at the neuron level and their abstract mathematical models (Wang, 2002, 2007a).

NeI is a branch of cognitive informatics, where memory is recognized as the foundation and platform of any natural or artificial intelligence (Wang, 2002, 2003, 2007a).

Neural Informatics Models of Human Memory

The human memory encompasses the sensory buffer memory, the short-term memory, the long-term memory (Baddeley, 1990; Rosenzweig et al., 1999; Smith, 1993; Squire, Knowlton, & Musen, 1993; Sternberg, 1998), and the action buffer memory (Wang & Wang, 2006; Wang, Wang, Patel, & Patel, 2006). Among these memories, the *Long-Term Memory* (LTM) is the permanent memory that human beings rely on for storing acquired information such as facts, knowledge, experiences, and part of skills and behaviors. For the latter, the main parts of skills and behaviors are stored in the action-buffer memory as logically modeled by Wang and Wang (2006), which is interconnected with the motor servo muscles.

An important theory of NeI pertains to the architecture of the memories in the brain as described next.

- **Definition 2:** The *Cognitive Models of Memory* (CMM) state that the architecture of human memory is parallel configured by the *Sensory Buffer Memory* (SBM), *Short-Term Memory* (STM), *Long-Term Memory*, and *Action-Buffer Memory* (ABM), that is:

$$\begin{aligned} \text{CMM} \triangleq & \text{SBM} \\ & \parallel \text{STM} \\ & \parallel \text{LTM} \\ & \parallel \text{ABM} \end{aligned} \quad (1)$$

where the ABM is newly identified by Wang and Wang (2006).

The major organ that accommodates memories in the brain is the cerebrum, or the cerebral cortex, in particular, the association and premotor cortex in the frontal lobe, the temporal lobe, sensory cortex in the frontal lobe, visual cortex in the occipital lobe, primary motor cortex in the frontal lobe, supplementary motor area in the frontal lobe, and procedural memory in cerebellum (Wang & Wang, 2006). The CMM model and the mapping of the four types of human memory onto the physiological organs in the brain reveal a set of fundamental mechanisms of NeI. The OAR model described in the following sections will provide a generic description of information/knowledge representation in the brain.

The theories of cognitive informatics and NeI explain a number of important phenomena in the study of natural intelligence. Some enlightening findings in cognitive informatics are as follows (Wang, 2007a; Wang & Wang, 2006):

- LTM establishment is a subconscious process;
- The LTM is established during sleeping;
- The major mechanism for LTM establishment is by sleeping;
- The general acquisition cycle of LTM is equal to or longer than 24 hours;
- The mechanism of LTM establishment is to update the entire memory of information represented as an OAR model in the brain;
- Eye movement and dreams play an important role in LTM creation.

The Hierarchical Neural Cluster (HNC) Model of Memory

- **Definition 3:** The functional model of LTM can be described as a set of *Hierarchical Neural Clusters* (HNCs) with partially connected *neurons* via *synapses*.

The HNC model can be illustrated as shown in Figure 1, where the LTM consists of dynamic and partially interconnected neural

networks. In the HNC model, a physiological connection between a pair of neurons via a synapse represents a logical *relation* between two abstract objects or concepts. The hierarchical and partially connected neural clusters are the foundation for information and knowledge representation in LTM.

Conventionally, LTM is perceived as static and fixed in adult brains (Baddeley, 1990; James, 1890; Rosenzweig et al., 1999; Smith, 1993; Sternberg, 1998). This was based on the observation that the capacity of adult brains has already reached a stable state and would not grow continuously. However, recent discoveries in neuroscience and cognitive informatics indicate that LTM is dynamically reconfiguring, particularly at the lower levels of the neural clusters (Rosenzweig et al., 1999; Squire et al., 1993; Wang & Wang, 2006). Otherwise, the mechanisms of memory establishment, enhancement, and evolution, which are functioning everyday in the brain, cannot be explained.

Actually, the previous perceptions in psychology and cognitive informatics are not contradictory with each other. The former states that the macro-number of neurons in adult brains will no longer increase significantly. The latter recognizes that information and knowledge should be physically and physiologically represented in LTM by something and in some way. Based on the latter, a cognitive model of LTM

Figure 1. LTM: Hierarchical and partially connected neural clusters

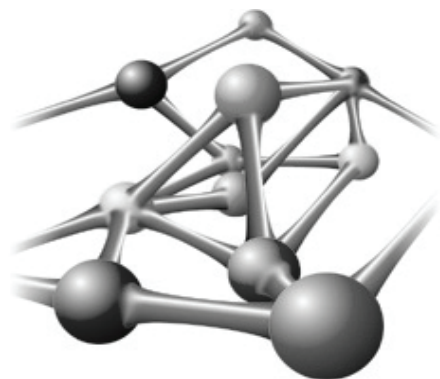

will be developed in the following sections to explain how information or knowledge is represented in LTM.

THE OAR MODEL FOR INTERNAL INFORMATION AND KNOWLEDGE REPRESENTATION

The preceding section described that the LTM does not only provide a foundation to, but also play the central role in human intelligence. According to the Layered Reference Model of the Brain (LRMB) (Wang et al., 2006), all the 39 cognitive processes of the brain at the layers of *sensation, memory, perception, action, meta cognitive functions, and higher cognitive functions* interact with LTM. Therefore, a generic memory model is sought in this section for understanding and simulating the roles of LTM in the brain's key cognitive processes such as learning, thinking, reasoning, and problem solving. As a result, the OAR model will be established for formally describing the mechanisms of LTM.

The Relational Metaphor of the OAR Model

In contrary to the traditional *container* metaphor, the human memory mechanism can be described by a *relational* metaphor. The new metaphor perceives that memory and knowledge are represented by the connections between neurons in the brain, rather than the neurons themselves as information containers. Therefore, the cognitive model of human memory, particularly LTM, can be described by three fundamental artifacts known as the object, attribute, and relation.

- **Definition 4:** *Object* is an abstraction of an external entity and/or internal concept.
- **Definition 5:** *Attribute* is a sub-object that is used to denote detailed properties and characteristics of the given object.
- **Definition 6:** *Relation* is a connection or inter-relationship between any pair of object-object, object-attribute, and attribute-attribute.

Based on the preceding definitions, the OAR model of the logical memory for information and knowledge is derived next.

- **Definition 7:** The *OAR model* of LTM can be described as a triple, that is:

$$OAR \triangleq (O, A, R) \tag{2.0}$$

where O is a finite set of objects identified by unique symbolic names, that is:

$$O = \{o_1, o_2, \dots, o_p, \dots, o_n\} \tag{2.1}$$

For each given $o_i \in O, 1 \leq i \leq n, A_i$ is a finite set of attributes for characterizing the object, that is:

$$A_i = \{A_{i1}, A_{i2}, \dots, A_{ij}, \dots, A_{im}\} \tag{2.2}$$

where each $o_i \in O$ or $A_{ij} \in A_p, 1 \leq i \leq n, 1 \leq j \leq m$, is physiologically implemented by a neuron in the brain.

Logically, each A_p may be defined by a set of generic and/or specific attributes such as:

$$A_i = \begin{array}{l} \text{physical attributes} \\ | \text{chemical attributes} \\ | \text{cognitive attributes} \\ \quad (\text{image, sound, touch, smell, taste}) \\ | \text{economical attributes} \\ | \text{time-related attributes} \\ | \text{space-related attributes} \\ | \text{categories} \\ | \text{specifications} \\ | \text{measurements} \\ | \text{usages} \\ | \text{others} \end{array} \tag{2.3}$$

where $|$ denotes an alternative (or) relation between defined items.

For each given $o_i \in O, 1 \leq i \leq n, R_i$ is a set of relations between o_i and other objects or attributes of other objects, that is:

$$R_i = \{R_{i1}, R_{i2}, \dots, R_{ik}, \dots, R_{iq}\} \tag{2.4}$$

where R_{ik} is a relation between two objects, o_i and o_j , and their attributes A_{ij} and $A_{ij'}$, $1 \leq i \leq n$, $1 \leq j \leq m$, that is:

$$R_{ik} = \begin{matrix} r(o_i, o_j) \\ | \\ r(o_i, A_{ij}) \\ | \\ r(A_{ij}, o_j) \\ | \\ r(A_{ij}, A_{ij'}), 1 \leq k \leq q \end{matrix} \quad (2.5)$$

Typically, R_i may be defined by a set of generic and/or specific relations such as:

$$R_i = \begin{matrix} \text{categories} \\ | \\ \text{types} \\ | \\ \text{entities (real-world objects)} \\ | \\ \text{artifacts (abstract concepts)} \\ | \\ \text{others} \end{matrix} \quad (2.6)$$

■

An abstract illustration of the OAR model between two objects is shown in Figure 2. The relations between objects can be established via pairs of object-object, object-attribute, and/or attribute-attribute. The connections could be highly complicated, while the mechanism is fairly simple that can be deducted to the physiological links of neurons via synapses in LTM.

It is noteworthy as in the OAR model that the *relations* themselves represent information and knowledge in the brain. The relational metaphor is totally different from the traditional container metaphor in neuropsychology and computer science, because the latter perceives that memory and knowledge are *stored* in individual neurons and the neurons function as containers.

• **Example 1:** According to the OAR model, an object of *tree*, t , in LTM of the brain can be represented as follows:

$$tree = (o, A, R) \\ = (t, A_t, R_t)$$

where:

- $o = t$
- $= tree$
- $A_t = \text{sign}$
- | real world reference (image)
- | other sensorial attributes (sound, touch, smell, and taste)
- | shape (category)
- | phonetics (/tri:/)
- | plant (category)
- | having a trunk (specific attribute 1)
- | with leaves (specific attribute 2)

Figure 2. The OAR model of memory architecture

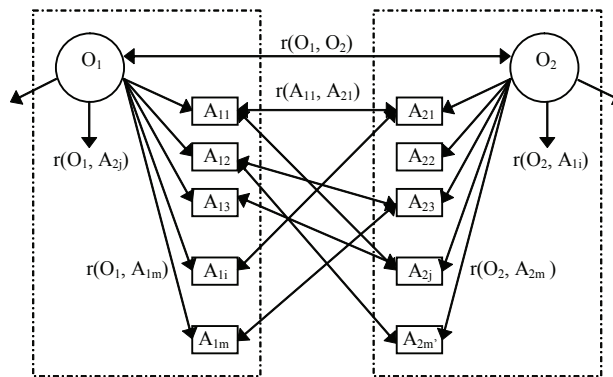

| green (specific attribute 3)
| ...

R_t = forest
| wood
| environment
| furniture
| house
| bird
| ...

Although the number of neurons in the brain is limited and stable, the possible relations between them may result in an explosive number of combinations that represent knowledge in the human memory. Therefore, the OAR model is capable of explaining the fundamental mechanisms of human memory creation, retention, and processing (Wang, 2002, 2003, 2007a; Wang & Ruhe, 2007).

The Extended OAR Model of Long-Term Memory

The OAR model developed in the preceding section provides a generic abstract concept model of the contents of LTM and the results of learning and other cognitive activities. Mapping it onto the cognitive structure of the brain, an extended OAR model of the brain, *EOAR*, is given in Figure 3, where the external world is represented by *real entities* (RE), and the internal world by *virtual entities* (VE) and *objects* (O). The internal world can be divided into two layers: the *image* layer and the *abstract* layer.

- **Definition 8:** The *Extended OAR model* of the brain, *EOAR*, states that the external world is represented by *real entities*, and the internal world by *virtual entities* and *objects*. The internal world can be divided

Figure 3. The EOAR model of the brain

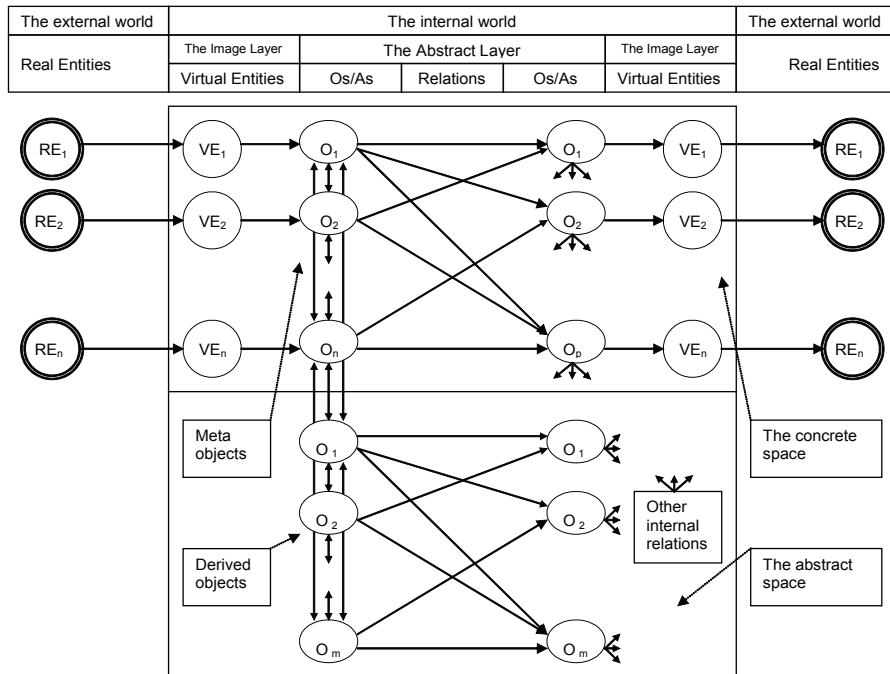

into two layers known as the *image layer* and the *abstract layer*.

The virtual entities are direct images of the external real-entities located at the image layer. The objects are abstract artifacts located at the abstract layer. The abstract layer is an advanced property of human brains. It is noteworthy that animal species have no such abstract layer in their brains. Therefore, they have no *indirect* or *abstract* thinking capability (Wang & Wang, 2006). In other words, abstract thinking is a unique power of the human brain known as the *qualitative* advantage of human brains. The other advantage of the human brain is the tremendous capacity of LTM in the cerebral cortex known as the *quantitative* advantages. On the basis of these two principal advantages as described in Theorem 1, humankind gains the power as human beings.

There are *meta objects* (O) and *derived objects* (O') at the abstract layer. The former are concrete objects directly corresponding to the virtual entities and then to the external world. The latter are abstracted objects that are derived internally and have no direct connection with the virtual entities or images of the real-entities such as abstract concepts, notions, ideas, and states of feelings. The objects on the brain's abstract layer can be further extended into a network of objects, attributes, and relations according to the EOAR model as shown in Figure 3. In Figure 3, the connections between objects/attributes (O/A) via relations are *partially* connected rather than fully connected, where the latter means each Q/A is connected to all others. In other words, it is not necessary to find a relation among all pairs of objects or attributes.

It is noteworthy that the higher level cognitive processes and consciousness, such as willingness, emotions, and desires, are results of both such internal states in the brain and current external stimuli. Detailed discussions may be referred to the LRMB model (Wang et al., 2006). It is also noteworthy that the cognitive model of the brain is looped. This means that an internal virtual entity is not only abstracted from the real-entity as shown on the

left-hand side in Figure 3, but also eventually connected to the entities on the right-hand side. This is the foundation of thinking, reasoning, and other high-level cognitive processes, in which internal information has to be related to the real-world entities, in order to enable the mental processes meaningfully embodied to real-world semantics.

LEARNING MECHANISMS EXPLAINED BY THE OAR MODEL

The OAR model created in the preceding sections provides a generic logic model for representing internal information and knowledge. This section demonstrates the applications of the OAR model in explaining the mental processes and cognitive mechanisms of learning and knowledge representation. The architectural aspect of knowledge representation is first discussed. On the understanding of the structure of knowledge and knowledge networks, the learning mechanisms will be described with the OAR model.

Knowledge Architecture Description by OAR-Based Concept Algebra

A concept network model may be described based on the OAR model for knowledge representation, which treats a concept as a basic and adaptive unit for modelling knowledge structures in the brain. On the basis of OAR, an abstract concept is a composition of the three essences, *O*, *A*, and *R*, in a coherent encapsulation.

- **Definition 9:** An *abstract concept* *c* is a 5-tuple, that is:

$$c \triangleq (O, A, R) = (O, A, R^c, R^f, R^o) \quad (3)$$

where

- *O* is a nonempty set of object of the concept, $O = \{o_1, o_2, \dots, o_m\}$.
- *A* is a nonempty set of attributes, $A = \{a_1, a_2, \dots, a_n\}$.

- $R^c \subseteq O \times A$ is a set of internal relations.
- $R^i \subseteq C' \times C$ is a set of input relations, where C' is a set of external concepts.
- $R^o \subseteq C \times C'$ is a set of output relations, where C' is a set of external concepts.

A structural concept model of $c = (O, A, R^c, R^i, R^o)$ can be illustrated in Figure 4, where $c, A, O,$ and $R, R = \{R^c, R^i, R^o\}$, denote the concept, its attributes, objects, and internal/external relations, respectively.

Using the abstract concept model and OAR, human *knowledge* can be modeled as a concept network. A set of rules for knowledge composition in order to construct complex and dynamic concept networks is described by concept algebra (Wang, 2006c).

- **Definition 10.** A *generic knowledge* K is an n -nary relation R_k among a set of n multiple concepts in C , that is:

$$K \triangleq R_k : (\prod_{i=1}^n C_i) \rightarrow C \quad (4)$$

where X denotes a series of Cartesian products, and $\bigcup_{i=1}^n C_i = C$.

In Definition 9, the relation $R_k, R_k \in \mathfrak{R}$, is one of the nine concept association operations as defined in concept algebra (Wang, 2006c), which serves as the knowledge composing

rules such as *inheritance, extension, tailoring, substitute, composition, decomposition, aggregation, specification, and instantiation* as given next:

$$\mathfrak{R} = \{\Rightarrow, \Rightarrow^+, \Rightarrow^-, \Rightarrow^{\sim}, \uplus, \cap, \Leftarrow, \vdash, \rightarrow\} \quad (5)$$

Because the relations between concepts are transitive, the generic topology of knowledge is a hierarchical network as stated next.

- **Theorem 2:** The *generic topology of abstract knowledge systems* K is a hierarchical concept network.

The previous theorem can be proved by the nine association rules \mathfrak{R} in concept algebra.

- **Definition 11:** A *concept network* CN is a hierarchical network of concepts inter-linked by the set of nine associations \mathfrak{R} defined in concept algebra, that is:

$$CN \triangleq \mathfrak{R} : \prod_{i=1}^n C_i \rightarrow \prod_{i=1}^n C_i \quad (6)$$

- **Theorem 3:** In a concept network CN , the *abstract levels of concepts* ℓ_c form a partial order of a series of increasing intensions, that is:

Figure 4. The structural model of concepts

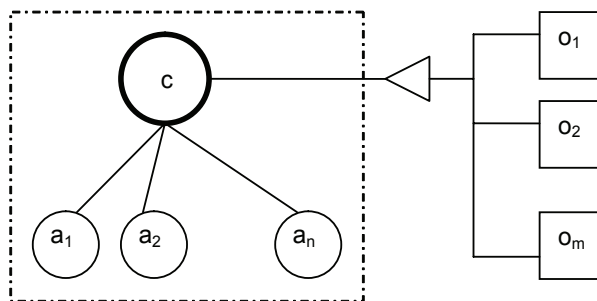

$$\ell_c = (\emptyset \preceq c_1 \preceq c_2 \preceq \dots \preceq c_n \preceq \dots \preceq \Omega) \quad (7)$$

where \emptyset is the *empty* concept $\emptyset = (\perp, \perp)$, and Ω the universal concept, $\Omega = (U, M)$, in which U denotes a finite or infinite nonempty set of objects, and M is a finite or infinite nonempty set of attributes, respectively.

Learning Mechanisms Explained by the OAR Model

- **Theorem 4.** The *principle of dynamic knowledge representation* states that internal memory in the form of an OAR structure can be updated by a composition of the existing OAR and the newly created sub-OAR (sOAR), that is:

$$\begin{aligned} OAR'ST &= OARST \uplus sOARST \\ &= OARST \uplus (O_s, A_s, R_s) \end{aligned} \quad (8)$$

where the composition operation \uplus on concepts is defined next.

- **Definition 12.** A *composition* of concept c from n subconcepts c_1, c_2, \dots, c_n , denoted by \uplus , is an integration of them that creates the new super concept c via concept conjunction, and establishes new associations between them, that is:

$$\begin{aligned} c(O, A, R^c, R^i, R^o) \uplus \biguplus_{i=1}^n c_i &\triangleq \\ c(O, A, R^c, R^i, R^o \mid O = \bigcup_{i=1}^n O_{c_i}, A = \bigcup_{i=1}^n A_{c_i}, \\ R^c = \bigcup_{i=1}^n (R^c_{c_i} \cup \{(c, c_i), (c_i, c)\}), R^i = \bigcup_{i=1}^n R^i_{c_i}, \\ R^o = \bigcup_{i=1}^n R^o_{c_i}) \\ \parallel \biguplus_{i=1}^n c_i(O_i, A_i, R^c_i, R^i_i, R^o_i \mid R^i_i = R^i_i \cup \{(c, c_i)\}, \\ R^o_i = R^o_i \cup \{(c_i, c)\}) \end{aligned} \quad (9)$$

As specified in Equation 9, the composition operation results in the generation of new internal relations $\Delta R^c = \bigcup_{i=1}^n \{(c, c_i), (c_i, c)\}$ that do not belong to any of its sub-concepts. It is also noteworthy that, during learning by concept composition, the existing knowledge in forms of the individual n concepts is changed and updated concurrently via the newly created input/output relations with the newly generated concept.

- **Corollary 1.** The *learning process* is a cognitive composition of a piece of newly acquired information and the existing knowledge in LTM in the form of the OAR-based knowledge networks.

Theorem 3 and Corollary 1 explain how existing knowledge is extended or updated in the OAR during learning, and how new knowledge is created in the OAR in human brains. It is noteworthy that knowledge composition based on OAR is an adaptive process that enables new knowledge to be integrated into the existing OAR network in LTM (Wang, 2006b, 2006c).

ESTIMATION OF MEMORY CAPACITY OF THE BRAIN BASED ON THE OAR MODEL

Comparing the human brain and those of other animals, the magnitude of the human memory shows a significant advantage. Therefore, to accurately determine the magnitude of human memory capacity is not only theoretically significant in cognitive informatics, but also practically useful to reveal the human potential. It is also helpful to perceive the status and limitations of current memory and computing technologies in computer science and artificial intelligence. The OAR model and the identification of the quantitative and qualitative advantages of human LTM enable rigorous estimation of the magnitude of the capacity of human memory.

According to the OAR model as given in Definition 7 and Figures 2 and 3, information is represented in the brain by relations, that is, a

logical model of synapses. Hence, the capacity of human memory is not only dependent on the number of neurons, but also the connections among them. This mechanism may result in an exponential combination to represent and store information in LTM of the brain. This also explains why the magnitude of neurons in an adult brain seems stable; however, huge amounts of information can be remembered throughout the entire life of a person.

- **Theorem 5.** The *human memory capacity model* states that, assuming there are n neurons in the brain, and on average there are s connections between a given neuron and a subset of the rest of them in the form of synapses, the magnitude of the brain's memory capacity C_m can be expressed by the following mathematical model:

$$C_m \triangleq C_n^s = \frac{n!}{s!(n-s)!} \tag{10}$$

where n is the total number of neurons, and s the number of average partial connections between neurons via synapses.

Equation 10 shows that the memory capacity problem in cognitive science and neuropsychology can be reduced to a classical combinatorial problem, with the total potential relational combinations, C_n^s , among all neurons ($n = 10^{11}$) and their *average* synapses ($s = 10^3$) to various related subset of entire neurons (Gabrieli, 1998; Marieb, 1992; Pinel, 1997). Therefore, the parameters of Equation 10 can be determined as follows:

$$\begin{aligned} C_m \triangleq C_n^s &= \frac{10^{11}!}{10^3!(10^{11}-10^3)!} \\ &= 10^{8,432} \quad [bit] \end{aligned} \tag{11}$$

Theorem 5 provides a mathematical explanation of the OAR model, which shows that the upper limit of the potential number of connections among neurons in the brain can be derived by the combination of a huge base and a large number of choices. This seems a simple

problem intuitively. However, it turns out to be extremely hard to solve and is almost intractable using any computer, because of the exponential complicity or the recursive computational costs for such large n and s . However, using the approximation theory and a computational algorithm (Wang, Liu, & Wang, 2003), the preceding result is obtained successfully.

The finding on the magnitude of the human memory capacity on the order as high as $10^{8,432}$ bits reveals an interesting mechanism of the brain. That is, the brain does not create new neurons to represent new information; instead it generates new synapses between the existing neurons in order to represent new information. The observation in neurophysiology that the number of neurons is kept stable rather than continuous increasing in adult brains (Marieb, 1992; Pinel, 1997; Rosenzweig et al., 1999) is an evidence for the relational cognitive model of information representation in human memory as described in this article.

The tremendous difference of memory magnitudes between human beings and computers demonstrates the efficiency of information representation, storage, and processing in human brains. Computers store data in a direct and unconsumed manner, while the brain stores information by relational neural clusters. The former can be accessed directly by explicit addresses and can be sorted, while the latter may only be retrieved by content-sensitive search and matching among neuron clusters where spatial connections and configurations themselves represent information.

CONCLUSION

Investigation into the cognitive models of information and knowledge representation in the brain and the capacity of the memory have been perceived to be one of the fundamental research areas that help to unveil the mechanisms and the potential of the brain. The OAR model developed in this article has provided a generic logic model for explaining both the form of internal knowledge representation and the mechanisms of LTM. It has also presented a reference model of information presentation

and storage for computing and information sciences. According to the OAR model, the human memory and knowledge have been represented by relational synaptic connections between neurons rather than by the neurons themselves as the traditional container metaphor described. It has been revealed that human knowledge can be formally described as dynamic composition of the existing OAR and the newly identified or generated objects, attributes, and/or relations.

Studies on various cognitive processes, such as problem solving, decision making, and comprehension, have demonstrated that the OAR model can be used as a foundation to rigorously explain the cognitive mechanisms of the brain. The OAR model has been applied to explain a wide range of cognitive mechanisms and mental processes in natural and artificial intelligence.

ACKNOWLEDGMENT

The author would like to acknowledge the Natural Science and Engineering Council of Canada (NSERC) for its support to this work. The author would like to thank the anonymous reviewers for their valuable comments and suggestions.

REFERENCES

- Baddeley, A. (1990). *Human memory: Theory and practice*. Needham Heights, MA: Allyn and Bacon.
- Gabrieli, J. D. E. (1998). Cognitive neuroscience of human memory. *Annual Review of Psychology*, 49, 87-115.
- Harnish, R. M. (2002). *Minds, brain, computers: An historical introduction to the foundations of cognitive science*. Oxford, UK: Blackwell Publishers, Ltd.
- James, W. (1890). *Principles of psychology*. New York: Holt.
- Jordan, D. W., & Smith, P. (1997). *Mathematical techniques: An introduction for the engineering, physical, and mathematical sciences* (2nd ed.). UK: Oxford University Press.
- Kotulak, R. (1997). *Inside the brain*. Kansas City, MO: Andrews McMeel Publishing Co.
- Leahey, T. H. (1997). *A history of psychology: Main currents in psychological thought* (4th ed.). Upper Saddle River, NJ: Prentice Hall Inc.
- Lecerf, C. (1998). Double loop flows and bidirectional Hebb's Law in neural networks. In *Proceedings of the Sixth DYNN'98, Stockholm*.
- Marieb, E. N. (1992). *Human anatomy and physiology* (2nd ed.). Redwood City, CA: The Benjamin/Cummings Publishing Co., Inc.
- Matlin, M. W. (1998). *Cognition* (4th ed.). Orlando, FL: Harcourt Brace College Publishers.
- Payne, D. G., & Wenger, M. J. (1998). *Cognitive psychology*. New York: Houghton Mifflin Co.
- Pinel, J. P. J. (1997). *Biopsychology* (3rd ed.). Needham Heights, MA: Allyn and Bacon.
- Rabin, M. O., & Scott, D. (1959). Finite automata and their decision problems. *IBM Journal of Research and Development*, 3, 114-125.
- Rosenzweig, M. R., Leiman, A. L., & Breedlove, S. M. (1999). *Biological psychology: An introduction to behavioral, cognitive, and clinical neuroscience* (2nd ed.). Sunderland, MS: Sinauer Associates, Inc., Publishers.
- Smith, R. E. (1993). *Psychology*. St. Paul, MN: West Publishing Co.
- Squire, L. R., Knowlton, B., & Musen, G. (1993). The structure and organization of memory. *Annual Review of Psychology*, 44, 453-459.
- Sternberg, R. J. (1998). *In search of the human mind* (2nd ed.). Orlando, FL: Harcourt Brace & Co.
- Turing, A. M. (1936). On computable numbers, with an application to the Entscheidungs problem. *Proceedings of London Mathematical Society*, 2(42), 230-265.
- Wang, Y. (2002). Keynote speech: On cognitive informatics. In *Proceedings of the First IEEE International Conference on Cognitive Informatics (ICCI'02)* (pp. 34-42). Calgary, Canada: IEEE CS Press.
- Wang, Y. (2003). Cognitive informatics: A new transdisciplinary research field. *Brain and Mind: A Transdisciplinary Journal of Neuroscience*

- and Neurophilosophy*, 4(2), 115-127.
- Wang, Y. (2006a). Keynote speech: Cognitive informatics—Towards the future generation computers that think and feel. In *Proceedings of the Fifth IEEE International Conference on Cognitive Informatics (ICCI'06)* (pp. 3-7). Beijing, China: IEEE CS Press.
- Wang, Y. (2006b). Invited plenary talk: Cognitive informatics and contemporary mathematics for knowledge representation and manipulation. In *Proceedings First International Conference on Rough Set and Knowledge Technology (RSKT'06), Lecture Notes in Artificial Intelligence, LNAI 4062* (pp. 69-78). Chongqing, China: Springer.
- Wang, Y. (2006c). On concept algebra and knowledge representation. In *Proceedings of the Fifth IEEE International Conference on Cognitive Informatics (ICCI'06)* (pp. 320-331). Beijing, China: IEEE CS Press.
- Wang, Y. (2007a). The theoretical framework of cognitive informatics. *The International Journal of Cognitive Informatics and Natural Intelligence (IJCiNi)*, 1(1), 1-27.
- Wang, Y. (2007b). *Software engineering foundations: A software science perspective*. CRC book series in software engineering (Vol. II). CRC Press.
- Wang, Y., Liu, D., & Wang, Y. (2003). Discovering the capacity of human memory. *Brain and Mind: A Transdisciplinary Journal of Neuroscience and Neurophilosophy*, 4(2), 189-198.
- Wang, Y., & Wang, Y. (2006). On cognitive informatics models of the brain. *IEEE Transactions on Systems, Man, and Cybernetics (C)*, 36(2), 16-20.
- Wang, Y., Wang, Y., Patel, S., & Patel, D. (2006). A Layered Reference Model of the Brain (LRMB). *IEEE Transactions on Systems, Man, and Cybernetics (C)*, 36(2), 124-133.

Yingxu Wang is professor of cognitive informatics and software engineering, director of International Center for Cognitive Informatics (ICfCI), and director of Theoretical and Empirical Software Engineering Research Center (TESERC) at the University of Calgary. He received a PhD in software engineering from The Nottingham Trent University, UK (1997), and a BSc in electrical engineering from Shanghai Tiedao University (1983). He was a visiting professor in the Computing Laboratory at Oxford University (1995), and has been a full professor since 1994. He is editor-in-chief of International Journal of Cognitive Informatics and Natural Intelligence (IJCiNi), editor-in-chief of IGP Book Series of Advances in Cognitive Informatics and Natural Intelligence, and editor of CRC Book Series in Software Engineering. He has published more than 290 papers and 10 books in software engineering and cognitive informatics, and won dozens of research achievement, best paper, and teaching awards in the last 28 years, particularly the IBC 21st Century Award for Achievement "in recognition of outstanding contribution in the field of cognitive informatics and software science."